

Product Catalog

Internal Hexagon

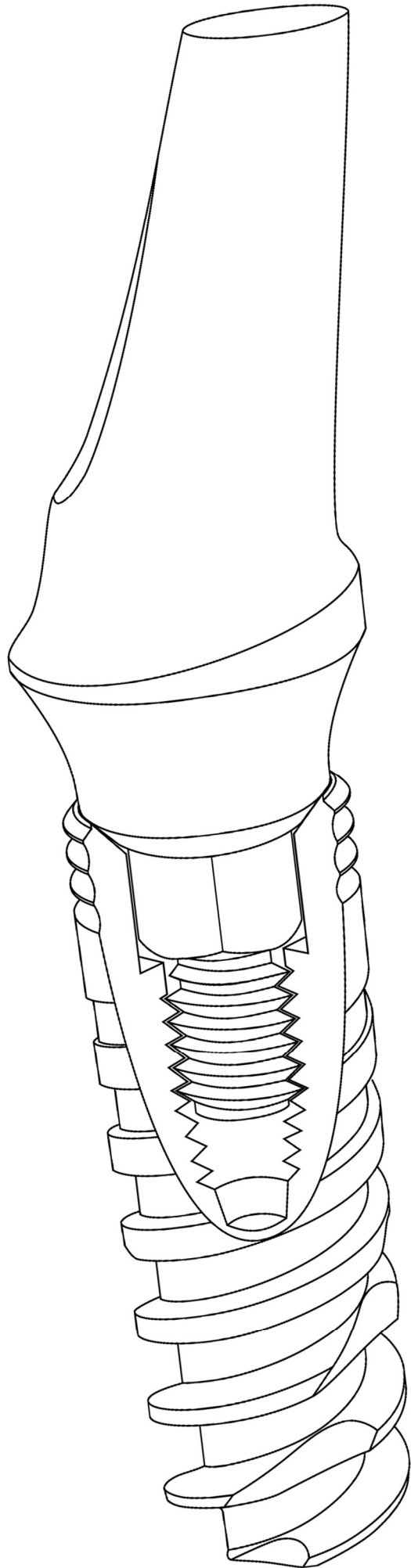

Contents

About US.....	4
Quality & Standards	5
Cleaning Process.....	6
Surface Treatment	6
IMPLANTS.....	7
MAER	8
RAGIL.....	10
Packaging.....	12
PROSTHETIC COMPONENTS.....	13
Healing cap	14
Analog / Impression Transfer	14
Straight Abutment.....	15
Abutment & Snap.....	15
Angled Abutment	16
Zirconia	16
ATC	16
Castable Abutment	17
Multi-Unit system.....	17
CAD CAM	18
Overdenture.....	18
SURGICAL INSTRUMENTS	19
Drill.....	20
Ratchet / Driver.....	21
.....	22
Tool / Surgical Kit	22
.....	22

About US

TOV Implant is a worldwide leader in the field of dental implants. We are Manufacturer and distributor of dental implants since 2009 and our implants can be found in thousands of healed persons around the globe.

TOV Implant has developed and manufactured a wide range of products for dental implants and restoration systems.

TOV Implant is a global strategic partner with leading international firms.

TOV Implant Vision:

Creating the highest quality implants, ensuring functional & esthetical solutions, while considering the long term and high success rate of the implant.

TOV Implant's Core Competences:

1. A small number of drills which prevent bone heating and increasing the recovery of the Implant.
2. Friendly & Easy surgical kits, simplifying surgical protocols.
3. The unique structure of the implant provides a special 360° stabilization of the implant, improving its quality and reducing bone restoration at the crestal part of the implant.
4. Sloping shoulder of the implant allows aesthetic reconstruction of the pre-implant soft Tissue, especially in the anterior aesthetic zone. They're easily achieved by design of the soft Tissue around the implant.
5. Implant design and knowledge transfer from bioengineering to the field of medicine, Allowing the use of TOV Implant implants in various and complicated clinical situations.
6. Unique driver for all range of prosthetic solutions.
7. Universal internal Hex connection (2.4mm)



Quality & Standards

TOV Implant management complies with ISO 13485:2016.

TOV Implant products are CE₀₄₈₂-approved.

TOV Implants are packaged in sterile gamma-irradiated tubes.

At TOV Implant, environmental responsibility in everything we do is more than lip service. The production plant is compliance with all current standards of environmental protection.

TOV Implant is certified and audited by the German notified body MEDCERT (0482).

Our policy is among the strictest in terms of quality and traceability.

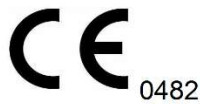

Cleaning Process

TOV Implant is using an advanced and thorough implant cleaning process for all dental implants to ensure surface structure and surface chemical composition and its purity grade. All implant products follow a multi-stage cleaning path before declared medically clean and ready for the packaging process.

Special Cleaning Considerations:

- Identity of any surface treatments that blast the implant
- Composition of the particles
- Identity of any treatments to remove particles from implant surfaces
- Identity of agents used in particle removal
- Chemical analysis of the surface to verify that any chemicals used to remove particles have been washed from the surface
- Photomicrographs of blasted surfaces to show whether there are particles remaining behind on the surface prior to sterilization by radiation, all implants go through a process for cleaning after the manufacturing process (pre-sterilization). The steps are: Washing after machining, aluminum blasting, and acid treatment.

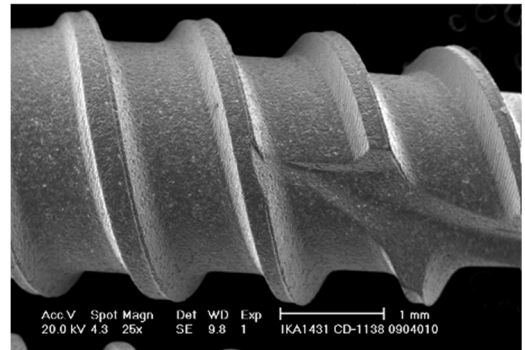
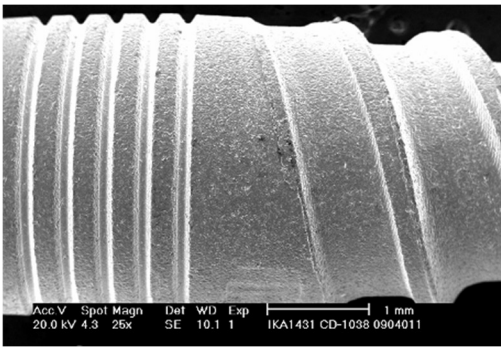

Surface Treatment

Titanium grade V (Ti 6Al 4V ELI) is a highly successful material for the fabrication of dental implants, on account of his favorable combination of properties such as low specific weight, high strength to weight ratio, high modulus of elasticity, very high corrosion resistance and excellent general biocompatibility.

The excellent biocompatibility and osseointegration capability of titanium is related to the properties of the material and its surface: -A dense, highly resistant passive oxide film that protects the underlying metal from further oxidation and corrosion. -A very low dissolution rate of the oxide film and an extremely low concentration of charged titanium corrosion product. Biocompatibility and bone-bonding strength of titanium alloy treated by sandblasting and anodic oxidation promote osseointegration at an early stage and stable fixation is bone tissue. The grade V titanium allows more change in design implant geometry, due to the mechanical strength of the grade V (40% stronger than grade 4). Implant geometry and macro- porous surface treatments play a role in the primary fixation and long-term mechanical stability.

The surface roughness and microgeometry of the titanium are achieved by surface blasting of Al₂O₃, followed by etching using HF, hydrochloric/sulfuric acid. The implants are sterilized by gamma radiation.

IMPLANTS

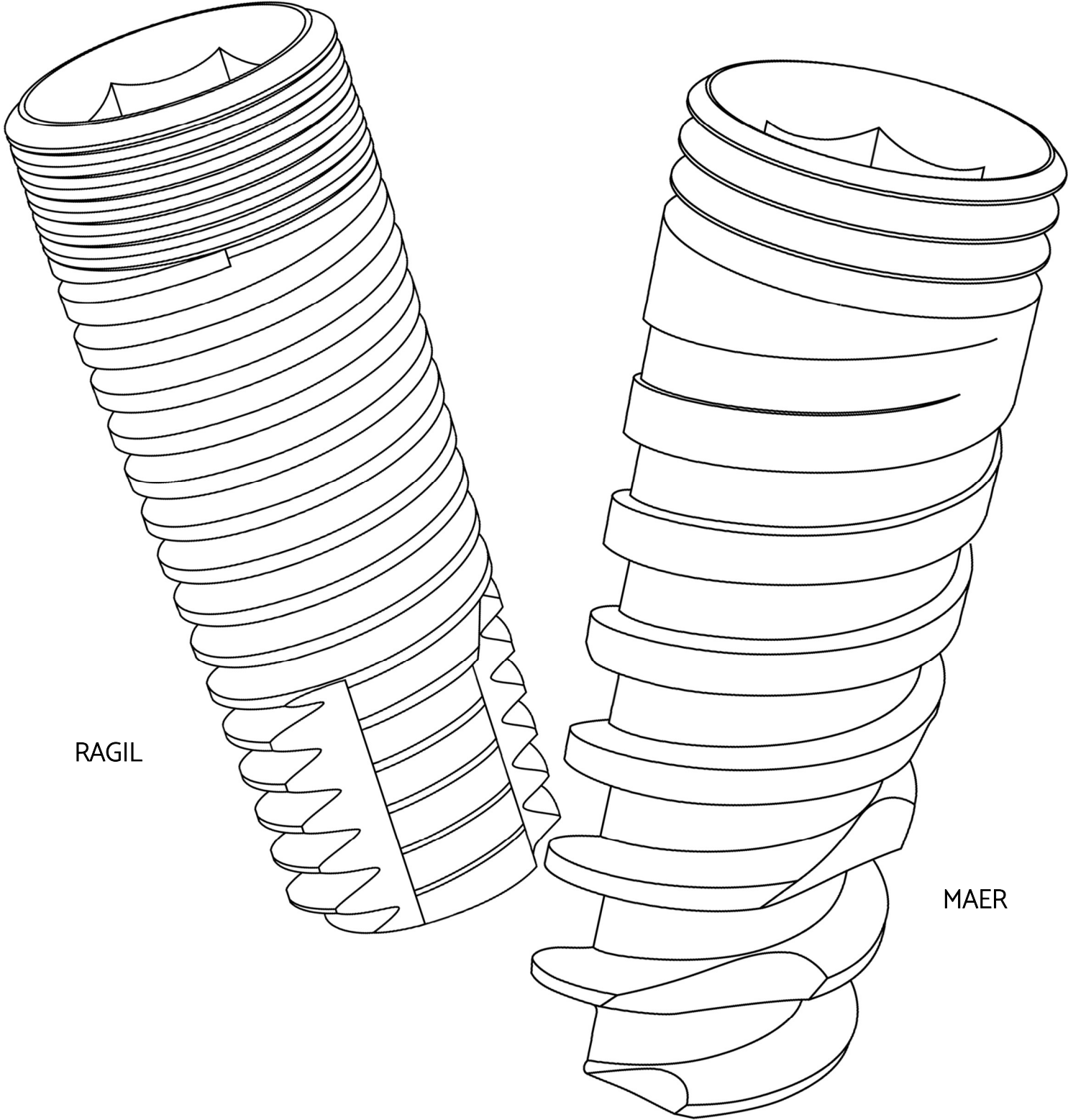

RAGIL

MAER

MAER

MAER is a spiral implant, it provides a very high primary stability. Its insertion is easy and stable, it is ideal for immediate implantation. It is self-tapping and self-drilling. Quality anchor allows the use of smaller implants, thus preserving more bone and peri-implant bone grafts reducing some cumbersome and costly. Adaptable to all clinical situations, it reduces drilling protocols.

Thus, a time saver but also a cooler bone, secures installation and improving bone healing. The three-dimensional positioning of the implant is facilitated and enables the installation of a width reduced bone. Its design medical grade V titanium alloy implant is ultra-resistant and completely bio compatible. Its micro sandblasting promotes assimilation and stimulating marrow, providing periodontal environment close to a natural tooth. Our comprehensive range of implants allows you to deal with all the cases, it has in addition, a very competitive price, ease of use and unrivaled unmatched reliability. What strengthen awareness Tov Implant®.

From Ø3 to Ø6

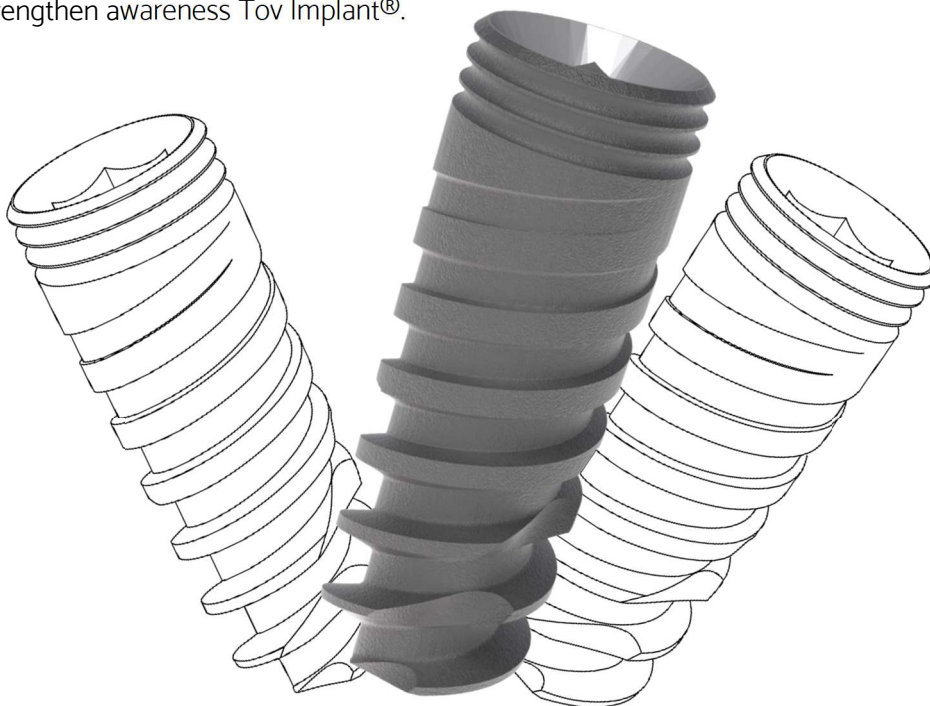

ADVANTAGES	INDICATIONS
<ul style="list-style-type: none"> - Better bone anchorage due to its conical form and coronary micro-threading - Simplified implantation and protocols (reduced number of drills) - Easy to use - Self-tapered and self-drilling - Very good bone stability following implantation - The ideal implant on narrow ridges without prior bone grafting - One-time implantation when associated to bone grafting - Faster healing - Less heating (limited drills) - Excellent primary anchorage with little bone height due to its coronary micro-threading (sinus floor lift) - Grade 5 titanium alloy, ultra-resistant implant 	<ul style="list-style-type: none"> - Great maxillary implantation - First choice implant for an immediate post extraction implantation - Facilitated implant placement in case of difficult extraction - Great primary anchorage, ideal for immediate loading - Great bone anchorage even in presence of reduced bone height - Very good bone stability following implantation - Ideal for vertical lift associated to biomaterials - Ideal for narrow ridges without expander or crestal spin

Titanium grade V (Ti 6Al 4V ELI)
 The titanium Implant surface was sandblasted with large grits and acid etched (SLA) to increase the implant surface for osseointegration

Body
 Tapered body for easy insertion
 Better primary stabilization



Connection "HX"
 Internal Hex 2.43mm/2.1mm
 One platform from Ø3.5 to Ø6
 Switching platform

Coronal Part
 Micro rings for decreased crestal stress
 Bone platform shifting
 Rough surface to the top

Apical "A"
 Aggressive apical blades
 Self tapping and drilling

Download IFU Here

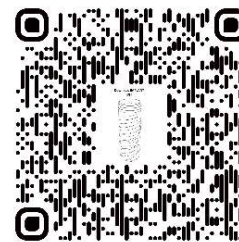

Ø	HX	A	Length	REF
Ø3	2.1	2.3	10	MAER3L10
			11.5	MAER3L11.5
			13	MAER3L 13
Ø3.5	2.43	2.4	6	MAER3.5L6
			8	MAER3.5L8
			10	MAER3.5L10
			11.5	MAER3.5L11.5
			13	MAER3.5L13
			16	MAER3.5L16
Ø3.75	2.43	3.1	6	MAER3.75L6
			8	MAER3.75L8
			10	MAER3.75L10
			11.5	MAER3.75L11.5
			13	MAER3.75L13
			16	MAER3.75L16
Ø4.2	2.43	3.5	6	MAER4.2L6
			8	MAER4.2L8
			10	MAER4.2L10
			11.5	MAER4.2L11.5
			13	MAER4.2L13
			16	MAER4.2L16
Ø5	2.43	4.2	6	MAER5L6
			8	MAER5L8
			10	MAER5L10
			11.5	MAER5L11.5
			13	MAER5L13
Ø6	2.43	5.2	6	MAER6L6
			8	MAER6L8
			10	MAER6L10
			11.5	MAER6L11.5
			13	MAER6L13

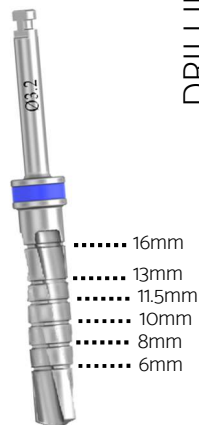

DRILLING PROCEDURE

Soft bone Type III & IV	Hard bone Type I & II
2.0	2.0
	2.8 cortical
2.0	2.0
2.5 / 2.8 cortical	2.5 / 2.8
	3.2 cortical
2.0	2.0
2.8	2.8
3.2 cortical	3.2
	3.65 cortical
2.0	2.0
2.8	2.8
3.2	3.2
3.65 cortical	3.65
	4.0 cortical
2.0	2.0
2.8	2.8
3.2	3.2
3.65	3.65
4.0/ 4.2 cortical	4.0
	4.2
	5.0 cortical
2.0	2.0
2.8	2.8
3.2	3.2
3.65	3.65
4.0/ 4.2	4.0
5.0 cortical	4.2
	5.0
	5.5 cortical

RAGIL

RAGIL is a polyvalent cylindrical conical implant for the procedures in a surgical or two steps. It is self-tapping with a wide sill thread. Quality anchor allows the use of smaller implants, thus preserving more bone and peri-implant bone grafts reducing some cumbersome. Adaptable to all clinical situations, it reduces drilling protocols. Thus, a time saver but also a cooler bone, secures installation and improving bone healing. The three-dimensional positioning of the implant is facilitated and enables the installation of a with reduced bone. Its design medical grade V titanium alloy implant is ultra-resistant and completely bio compatible. Its micro-sandblasting promotes assimilation and stimulating marrow, providing periodontal environment close to a natural tooth. Our comprehensive range of implants allows you to deal with all clinical cases.

From Ø3.3 to Ø6

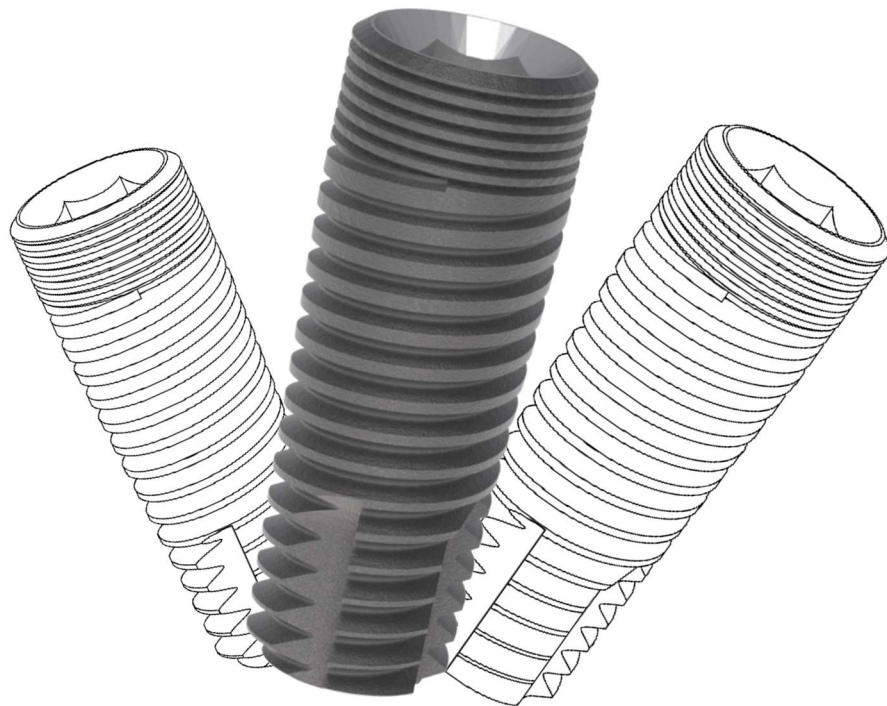

ADVANTAGES	INDICATIONS
<ul style="list-style-type: none"> - Constant and inclined geometry of the threads all along the implant enabling a regular and smooth insertion - Self-tapered implant without risks of internal and external cortical penetrations - Smooth and coherent surgical procedure - Increased primary stability due to its coronary flaring - Coronary micro-threading enabling an excellent primary stability - In a dense bone, insertion is without tension or pressure, due to a more constant threading - Higher contact surface with the bone compared to the conical implant - Better stabilization of the implant in post extraction alveolitis - Time limited bone resorption 	<ul style="list-style-type: none"> - Mandibular implantation - Dense to very dense bone - Full adaptation of difficult post extraction alveoli - Major indication for molar implantation

Titanium grade V (Ti 6Al 4V ELI)

The titanium Implant surface was sandblasted with large grits and acid etched (SLA) to increase the implant surface for osseointegration

Body

Cylindrical conical body for easy insertion
Minimal pressure on hard bone
Better primary stabilization



Connection "HX"

Internal Hex 2.43mm One platform from Ø3.35 to Ø6 Switching platform

Coronal Part

Micro rings for decreased crestal stress
Bone platform shifting
Rough surface to the top

Apical "A"

Self-tapping
Prevent damage to anatomical structures

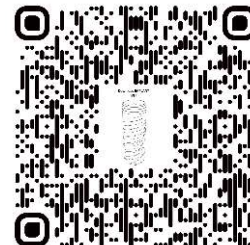

Download IFU Here

ø	HX	A	Length	REF
ø3.3	2.43	2.8	8	RAGIL3.5L8
			10	RAGIL3.5L10
			11.5	RAGIL3.5L11.5
			13	RAGIL3.5L13
			16	RAGIL3.5L16
ø3.75	2.43	3.2	8	RAGIL3.75L8
			10	RAGIL3.75L10
			11.5	RAGIL3.75L11.5
			13	RAGIL3.75L13
			16	RAGIL3.75L16
Ø4.2	2.43	3.6	8	RAGIL4.2L8
			10	RAGIL4.2L10
			11.5	RAGIL4.2L11.5
			13	RAGIL4.2L13
			16	RAGIL4.2L16
Ø5	2.43	4.2	8	RAGIL5L8
			10	RAGIL5L10
			11.5	RAGIL5L11.5
			13	RAGIL5L13
ø6	2.43	5.2	8	RAGIL6L8
			10	RAGIL6L10
			11.5	RAGIL6L11.5

DRILLING PROCEDURE



- 16mm
- 13mm
- 11.5mm
- 10mm
- 8mm
- 6mm

Soft bone Type III & IV	Hard bone Type I & II
2.0	2.0
2.5 / 2.8	2.5 / 2.8
	3.2
2.0	2.0
2.8	2.8
3.2	3.2
3.65	3.65
	4.0
2.0	2.0
2.8	2.8
3.2	3.2
3.65	3.65
4.0 / 4.2	4.0
	4.2
	5.0
2.0	2.0
2.8	2.8
3.2	3.2
3.65	3.65
4.0 / 4.2	4.0
5	4.2
	5.0
	5.5

Packaging

All implants are delivered in double sterile packaging. The outer box houses a vial that includes the pre-mounted implant covered with implant guard.

Each pack includes cover screw and carrier mount. The pack is labeled with the implant type, length and color coded for implant diameter. A sticky label displays all pertinent information regarding the implant. Two labels are supplied in the package.

Implant and all related components in tubes pack sterilized by gamma irradiation. Labeling information is in one of the sections inside the pack. Sterility is assured unless the pouch is damaged or opened.

Other non-sterile components used in the laboratory are supplied clean but not sterile. These are: laboratory analogs, castable waxing sleeves, casting precision tools and abutments with plastic sleeves and other prosthetic components.

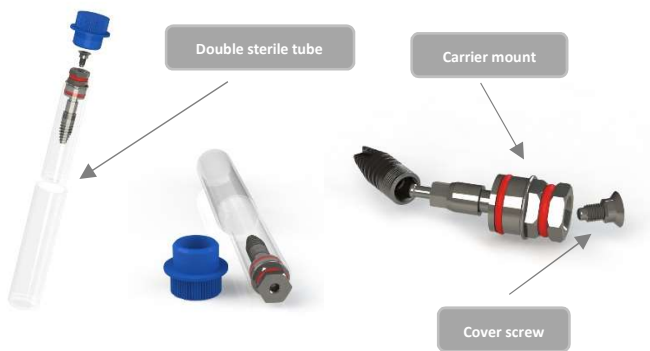

Color Coding

Ø3
Ø3.5
Ø3.75
Ø4.2
Ø5
Ø6

LABELLING SYMBOLS

The following symbols are used on the packaging label

USE BY DATE	
CATALOG REFERENCE	
LOT NUMBER	
DO NOT RE-USE	
STERILIZED BY IRRADIATION	
CAUTION, CONSULT ACCOMPANYING DOCUMENTS	
REGULATORY COMPLIANCE	
MANUFACTURER	
DO NOT USE IF PACKAGING IS BROKEN OR DAMAGED	
EU REPRESENTATIVE	
DO NOT RESTERILIZE	
NON STERILE	

Download Implant IFU

Download Prosthetic & instruments IFU Here

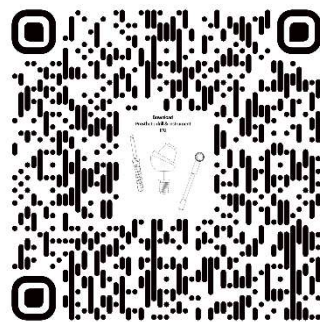

PROSTHETIC COMPONENTS

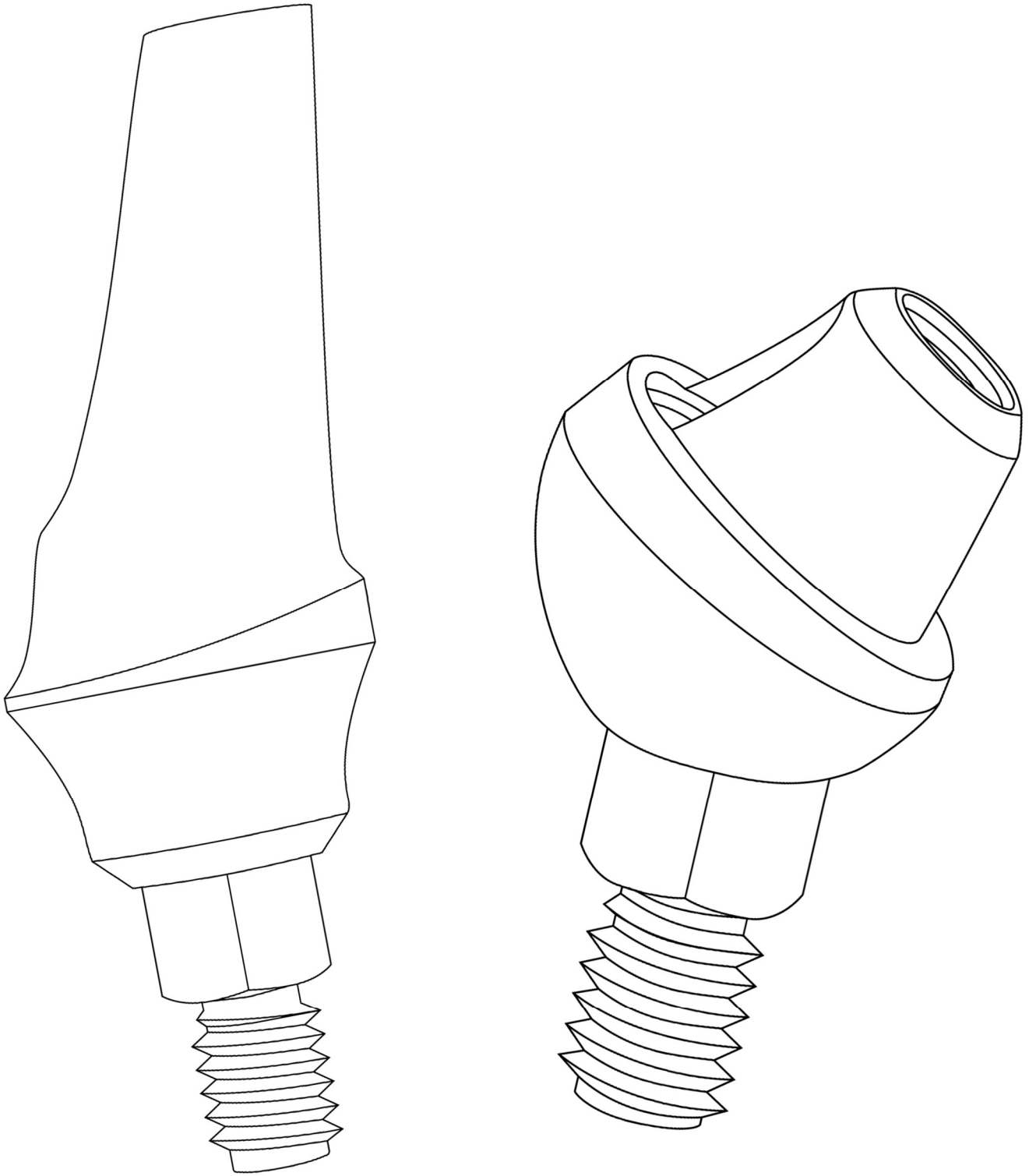

Healing Cap

Healing cap
Titanium



Platform	D
Slim	3mm
Standard	4.6mm
Large	5.5mm

Platform	2mm	3mm	4mm	5mm	6mm	7mm
Slim	VCSL2	VCSL3	VCSL4	VCSL5	-	-
Standard	VSC2	VSC3	VSC4	VSC5	VSC6	VSC7
Large	VCL2	VCL3	VCL4	VCL5	VCL6	-
Narrow	-	VCN3	-	VCN5	-	VCN7

Slim Platform suitable for Ø3 Slim Implant only

Impression

Analog / Impression Transfer

Analog



Transfer



Slim	Standard	Large	Multi-Unit
ANSL	ANS	ANW	AMU
Ø3mm	Ø3.75mm	Ø5mm	

	Slim	Long	Short	Multi-Unit
Clip	-	TECLL	TECLS	TAMU
Open	TESSL	TESL	TESS	
Close	-	TESCL	TESCS	
	Ø4.1L10.6	Ø4.1L13mm	Ø4.1L9mm	

Screw

Prosthetic screw is included with all abutments

REF: VISP

L1	L2	L3
83	2.5	2.8

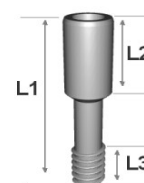

Straight abutment

Straight Abutment

Titanium

With shoulder



Platform	D
Slim	3mm
Standard	4.5mm
Large	5.5mm

Platform	1mm	2mm	3mm	4mm
Slim	PDASL1	PDASL2	PDASL3	-
Standard	PDAS1	PDAS2	PDAS3	PDAS4
Large	PDAL1	PDAL2	PDAL3	PDAL4

Slim Platform suitable for Ø3 Slim Implant only

Without shoulder

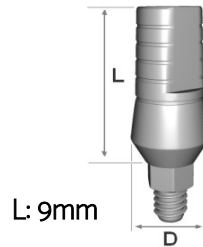

Platform	D
Slim	3mm
Narrow	3.8mm
Standard	4.7mm
Large	5.5mm

Ø	Slim	Narrow	Standard	Large
	PDSSL	PDSN	PDSS	PDSL

Slim Platform suitable for Ø3 Slim Implant only

Abutment & Snap



Set include abutment & snap transfer

Platform	1mm	2mm	3mm	4mm	5mm
Standard	PDSN1	PDSN2	PDSN3	PDSN4	PDSN5

Angled abutment

Angled Abutment

Titanium

With shoulder



Without shoulder



Degree	1mm	2mm	3mm	4mm
15°	PAA15S1	PAA15S2	PAA15S3	PAA15S4
25°	PAA25S1	PAA25S2	PAA25S3	-

Ø4.5 mm

15°	PAS15S
25°	PAS25S

Zirconia abutment

Zirconia



	1mm	2mm	3mm
Straight	PDZ1	PDZ2	PDZ3
15°	PAZ151	PAZ152	PAZ153

ATC

ATC

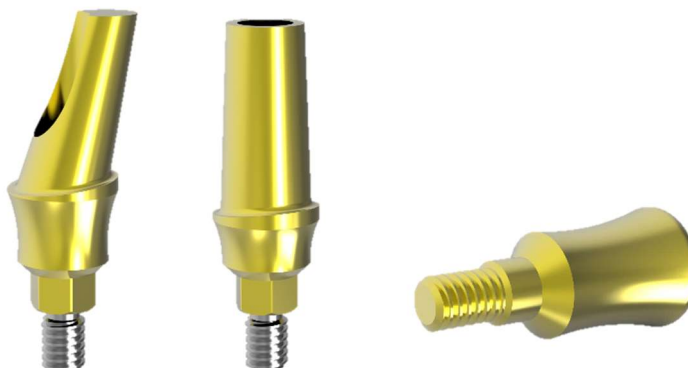

	1mm	2mm	3mm	4mm	6mm
Straight	PDATC1	PDATC2	PDATC3	PDATC4	-
15°	PAATC151	PAATC152	PAATC153	-	-
25°	PAATC251	PAATC252	PAATC253	-	-
Healing Cap	-	VCATC2	-	VCATC4	VCATC6

Castable abutment

Castable Abutment

Plastic



	Standard	Slim
Hexed	PCS	PCSL
Non-Hexed	PCSNH	-

	15°	25°
1mm	PCS15S1	PCS25S1
2mm	PCS15S2	PCS25S2
3mm	PCS15S3	PCS25S3

Slim Platform suitable for Ø3 Slim Implant only



Titanium

Cobalt chrome

Hexed	Hexed	Non-Hexed
UCLTH	UCLCCH	UCLCCNH
Titanium	Cobalt chrome	

Multi-unit system

Multi-Unit system



Set.

	1mm	2mm	3mm	4mm
Straight	EMU1	EMU2	EMU3	EMU4
18°	AMU181	AMU182		
30°	AMU301	AMU302		



Titanium	Plastic
TAMU	PAMU



Straight
HCMU

CAD CAM

CAD CAM

3D Library available for main CAD CAM system



Hexed	Multi-Unit
SCBDY	SCBDMU



Multi-Unit	Hexed	Non-Hexed	Hexed	Non-Hexed
CADMU	BTH	BTNH	BTSIRH	BTSIRNH

Sirona™

Overdenture

Overdenture

Ball attachment



Set.

Height	1mm	2mm	3mm	4mm
Standard	AB1	AB2	AB3	AB4
Slim	ABSL1	ABSL2	ABSL3	ABSL4

Slim Platform suitable for Ø3 Slim Implant only

Retentor



Set.

Height	1mm	2mm	3mm	4mm	5mm	6mm
Standard	RET1	RET2	RET3	RET4	RET5	RET6

SURGICAL INSTRUMENTS

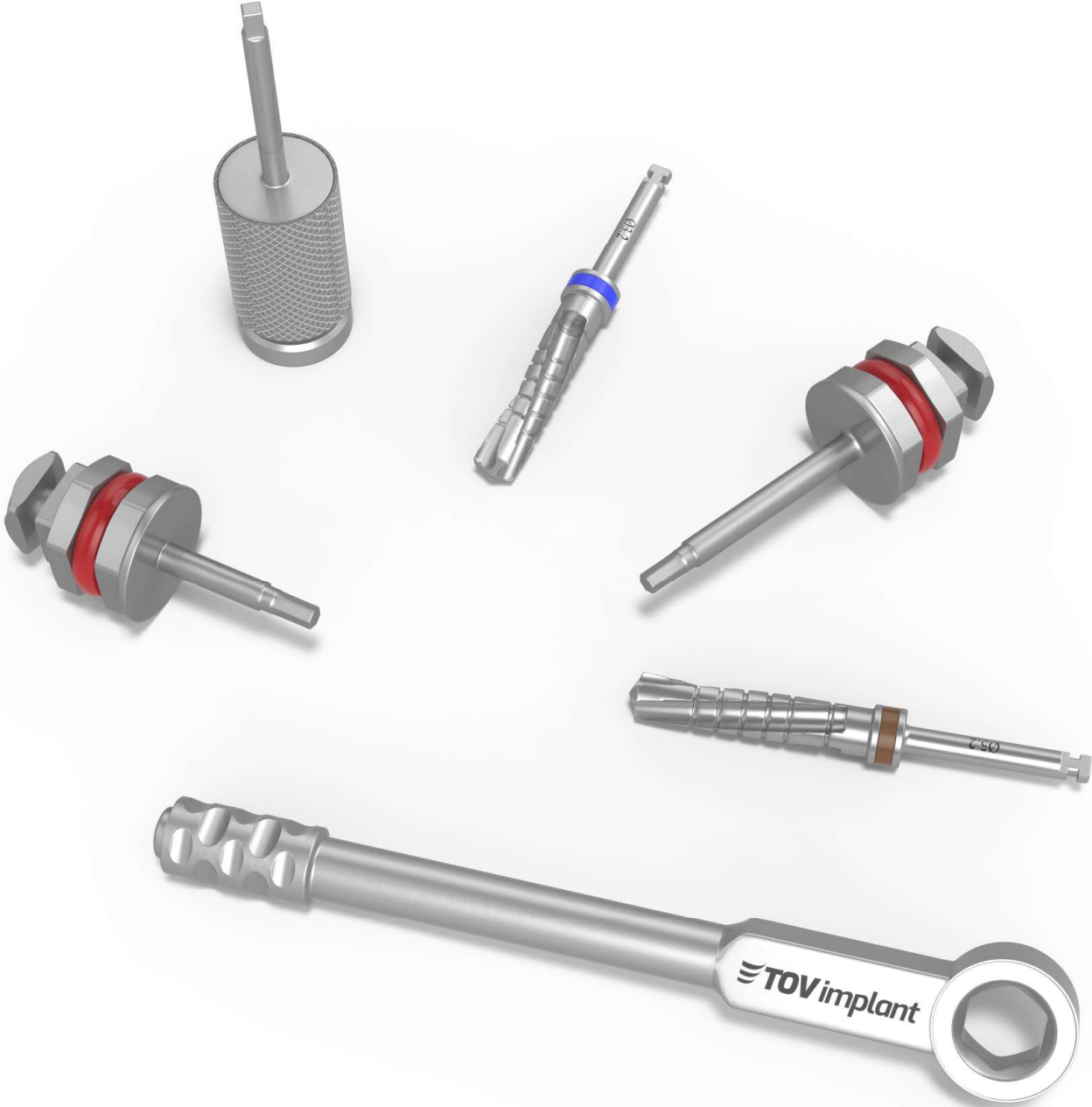

Drill

Drill

Standard straight twisted drill

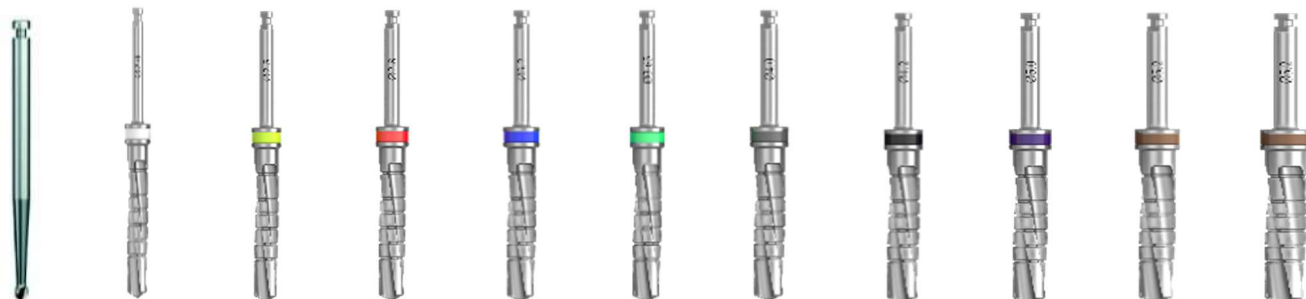

Ø1.9mm	Ø2mm	Ø2.5mm	Ø2.8mm	Ø3.2mm	Ø3.65mm	Ø4mm	Ø4.2mm	Ø5mm	Ø5.2mm	Ø5.5mm
FORP	FOR2	FOR2.5	FOR2.8	FOR3.2	FOR3.65	FOR4	FOR4.2	FOR5	FOR5.2	FOR5.5

Conical drill



Ø2.2mm	Ø2.7mm	Ø3.2mm	Ø4mm	Ø5.5mm
Ø1.6mm	Ø1.6mm	Ø2mm	Ø2.7mm	Ø3.1mm
CFOR2.2	CFOR2.7	CFOR3.2	CFOR4	CFOR5.5

Stopper set



Ø2mm	Ø2.8mm	Ø3.2mm	Ø3.65mm
6-13mm	6-13mm	6-13mm	6-13mm
STOPKIT			

Countersink



Ø 3.75/4.2	Ø 5/6
CKFOR375	CKFOR5

Ratchet / Driver

Standard ratchet wrench



RATW

Torque ratchet



TRATW

Hex Driver

Hex 1.25 Prosthetic



Long	Short
HXDPL	HXDPS

Hex 2.4 Implant

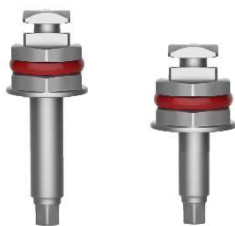

Long	Short
HXDIL	HXDIS

Hex 2 Implant Slim



Long	Short
HXDISLL	HXDISLS

Hand Driver

Motor mount

Hand 1.25 Prosthetic



Long	Short
HDL	HDS

1.25 Prosthetic



Long	Short
MMPL	MMPS

2.4 Implant

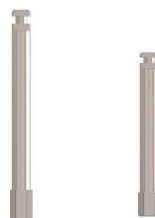

Long	Short
MMIL	MMIS

2.0 Implant Slim

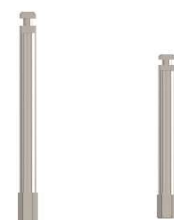

Long	Short
MMISLL	MMISLS

Tools

Tool / Surgical Kit

Surgical screwdriver



RATW

Drill extender



RATW

Hand adaptor



ADAPT

Surgical kit

Medium Kit

REF: SKM

Standard Ratchet wrench
 Mark Drill $\varnothing 1.9$
 Drill $\varnothing 2/2.8/3.2/3.65/4.2/5.2$
 Drill Extender
 Hand driver Long/ Short

Parallel Pin long / short
 1.25 Hex driver Long/ Short
 2.42 Hex driver Long
 2.42 Motor Mount Long/ Short
 1.25 Motor Mount



Large Kit

REF: SKL

Standard Ratchet wrench
 Mark Drill $\varnothing 1.9$
 Drill $\varnothing 2/2.5/2.8/3.2/3.65/4/4.2/5.5$
 Countersink $\varnothing 3.75/\varnothing 5$
 Drill Extender
 Hand driver Long/ Short
 Hand adaptor

Parallel Pin long / short
 1.25 Hex driver Long/ Short
 2.42 Hex driver Long/ Short
 2.42 Motor Mount Long/ Short
 1.25 Motor Mount Long/ Short
 5 spares





 ***TOV implant***



Visit Us

www.tov-implant.com

Product availability may vary between countries

TOV Implant Ltd. All rights reserved.

contact@tov-implant.com



Authorized distributor



 **TOV implant**

CE 0482

